

WINCORE™

WINDOWS & DOORS

250 Staunton Turnpike, Parkersburg, WV 26104

8800 Series ("HVHZ") Vinyl Fixed Window "IMPACT"

GENERAL NOTES

1. This product has been evaluated and is in compliance with the 8th Edition (2023) Florida Building Code (FBC) structural requirements including the "High Velocity Hurricane Zone" (HVHZ).
2. Product anchors shall be as listed and spaced as shown on details. Anchor embedment to base material shall be beyond wall dressing or stucco.
3. When used in the "HVHZ", this product complies with Section 1626 of the FBC and does not require an impact resistant covering.
4. For 2x stud framing construction, anchoring of these units shall be the same as that shown for 2x buck masonry construction.
5. Site conditions that deviate from the details of this drawing require further engineering analysis by a licensed engineer or registered architect.
6. This product meets the water infiltration requirements for the "HVHZ".

TABLE OF CONTENTS	
SHEET#	DESCRIPTION
1	Typical elevations, design pressures and general notes
2	Horizontal cross sections
3	Buck & frame anchoring
4	Bill of materials, glazing details & components

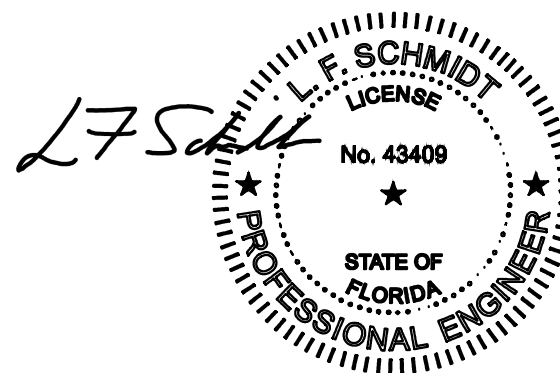

This item has been digitally signed and sealed by L. F. Schmidt, P.E. on the date adjacent to the seal.

Printed copies of this document are not considered signed and sealed and the signature must be verified on any electronic copies.

THIS PRODUCT APPROVAL IS VALID ONLY FOR THE STATE OF FLORIDA

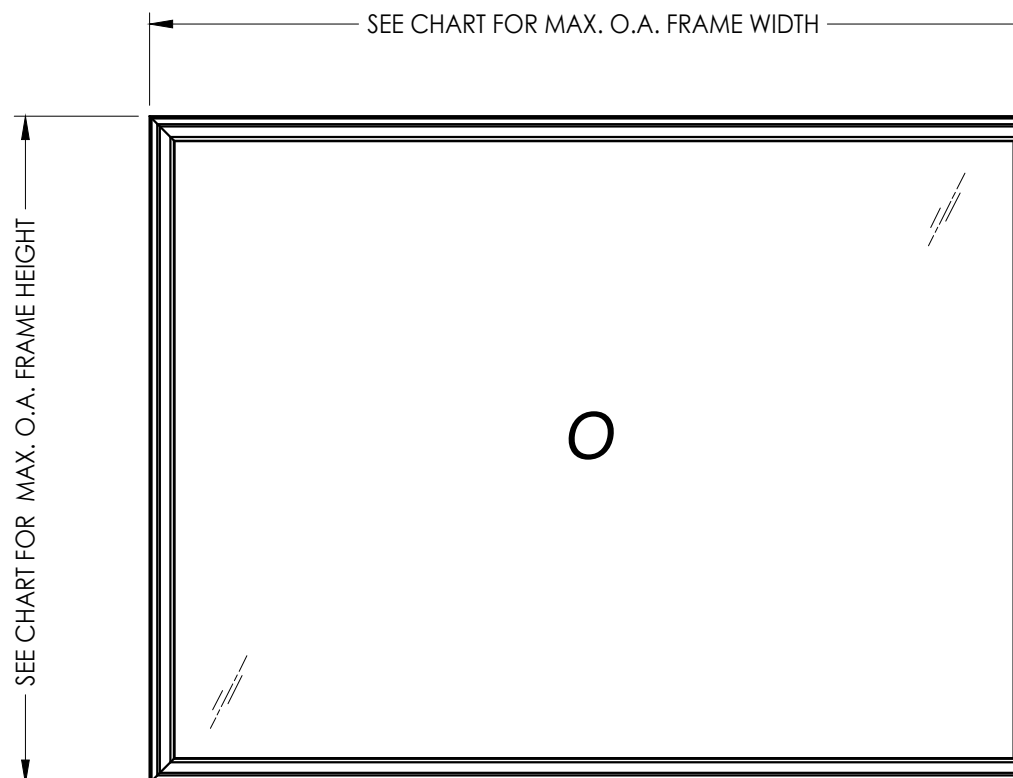

NOTE: HORIZONTAL OR VERTICAL ORIENTATION IS ALLOWED

MAX. FRAME DIMENSION	MAX. D.L.O. DIMENSION	GLASS TYPE	DESIGN PRESSURE (PSF)	
			POSITIVE	NEGATIVE
84.0" X 54.0"	78.75" X 48.75"	G2	+50.0	-50.0
76.0" X 63.0"	70.75" X 57.75"	G2	+65.0	-70.0
76.0" X 48.0"	70.75" X 42.75"	G1	+65.0	-65.0

Documents Prepared By:
Lyndon F. Schmidt
P.E. No. 43409

RW BUILDING CONSULTANTS, INC.
P.O. Box 230, Vairico, FL 33595
Phone No.: 813.659.9197
FBPE Registry No. 9813

PRODUCT: 8800 SERIES VINYL FIXED WINDOW
PART OR ASSEMBLY: TYPICAL ELEVATION, DESIGN PRESSURES & GENERAL NOTES

NO.	DATE	BY	REVISIONS
2	7/06/23	LFS	UPDATE TO 8TH ED. (2023) FBC
1	7/06/20	LFS	UPDATE TO 7TH ED. (2020) FBC

DATE: 4/07/20

SCALE: N.T.S.

DWG. BY: TJ

CHK. BY: LFS

DRAWING NO.: FL-15816.15

SHEET 1 OF 4

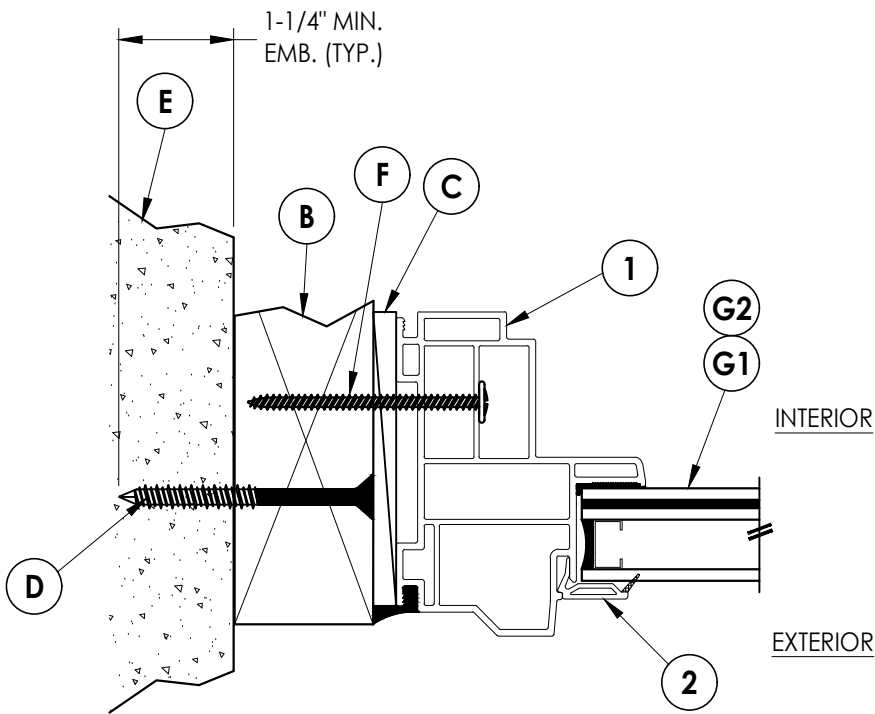

1 HORIZONTAL CROSS SECTION
2 Shown w/ 2X buck

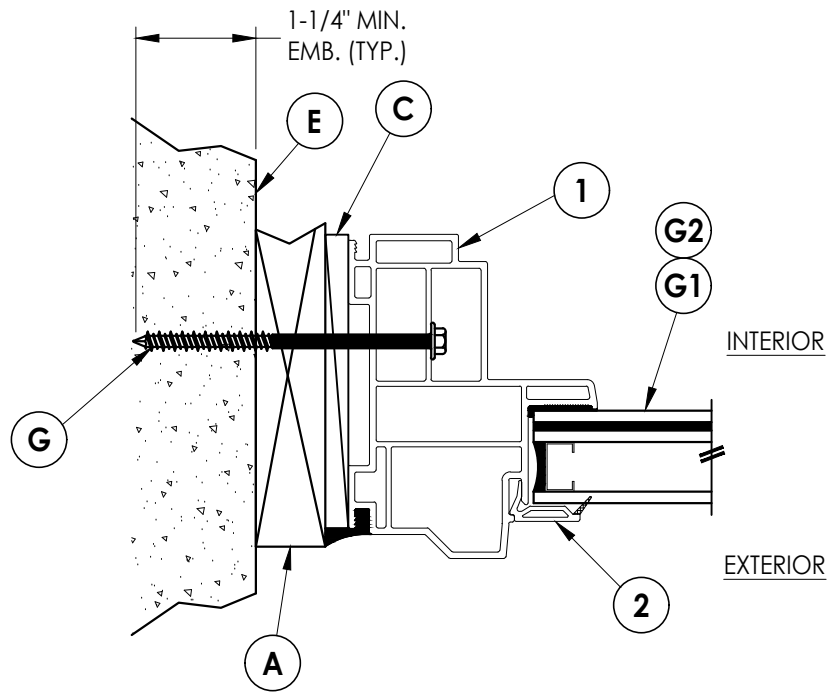

2 HORIZONTAL CROSS SECTION
2 Shown w/ 1X buck

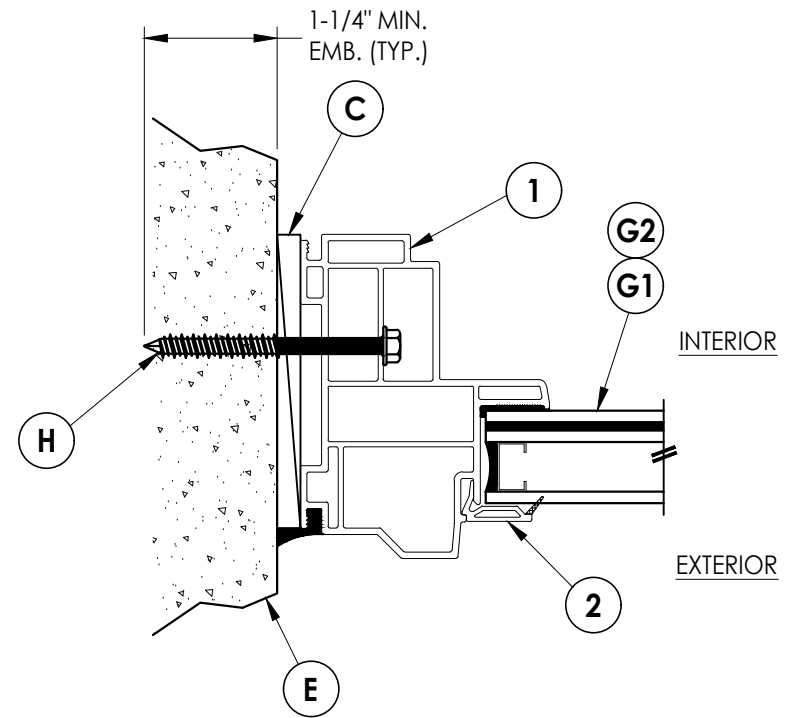

3 HORIZONTAL CROSS SECTION
2 Shown direct to masonry

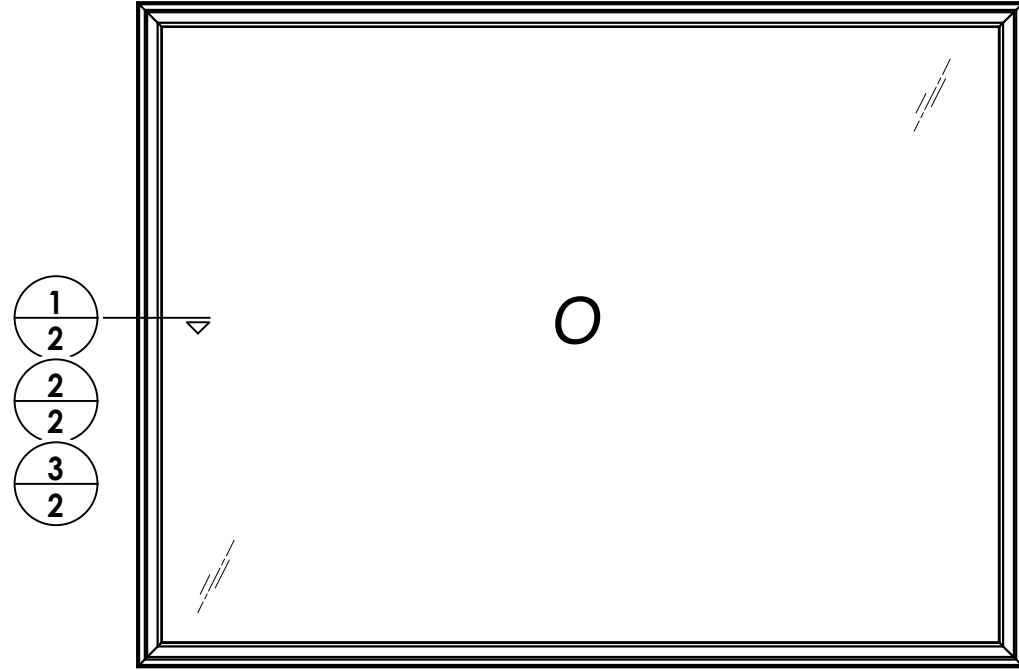

PRODUCT:		
8800 SERIES	VINYL FIXED WINDOW	
PART OR ASSEMBLY:		
HORIZONTAL CROSS SECTIONS		
NO.	DATE	BY
2	7/06/23	LFS
1	7/06/20	FBC

DATE:	4/07/20
SCALE:	N.T.S.
DWG. BY:	TJ
CHK. BY:	LFS
DRAWING NO.:	FL-15816.15
SHEET	2 OF 4

Documents Prepared By:
 Lyndon F. Schmidt
 P.E. No. 43409

RW BUILDING CONSULTANTS, INC.
 P.O. Box 230, Vairico, FL 33595
 Phone No.: 813.659.9197
 FBPE Registry No. 9813

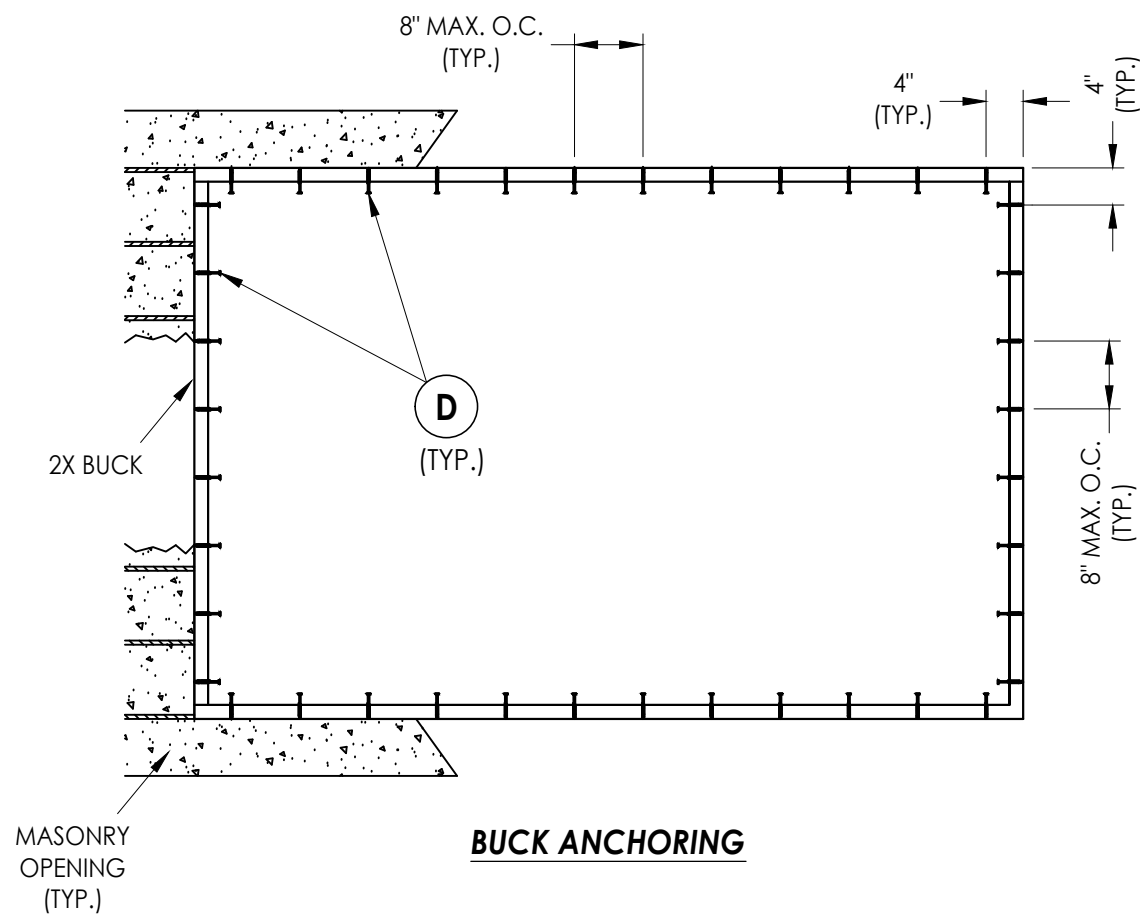

BUCK ANCHORING

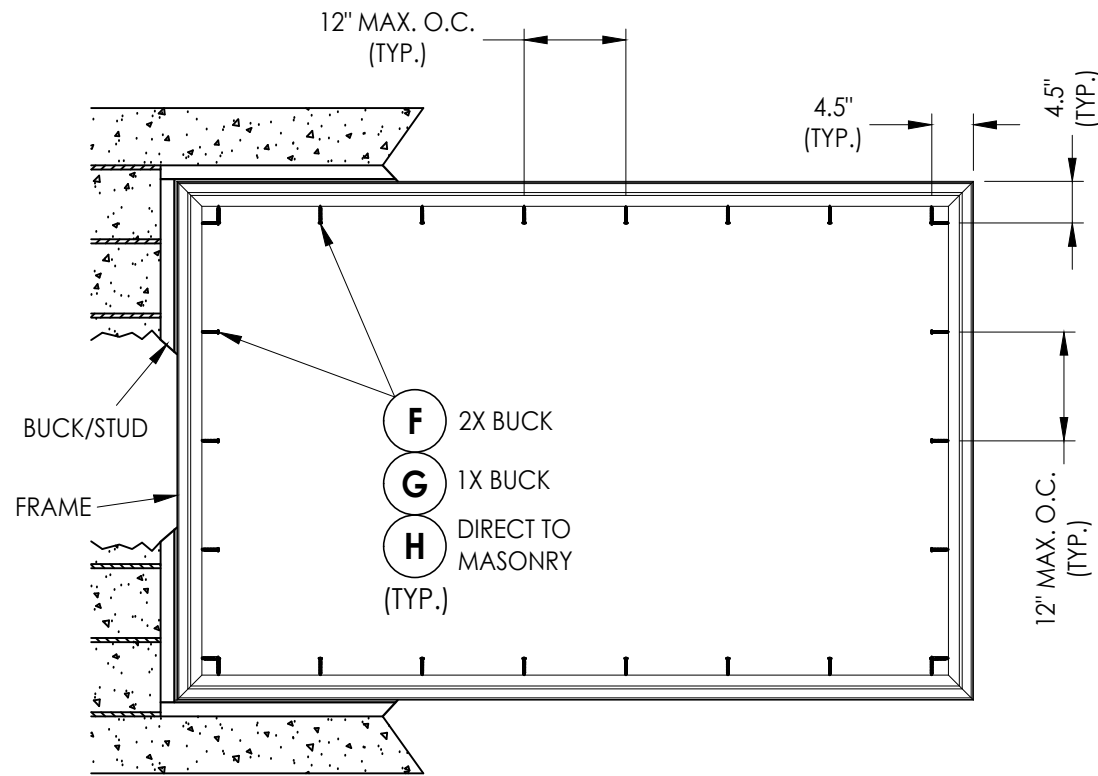

FRAME ANCHORING

CONCRETE ANCHOR NOTES:

- Concrete anchor locations at the corners may be adjusted to maintain the min. edge distance to mortar joints.
- Concrete anchor locations noted as "MAX. ON CENTER" must be adjusted to maintain the min. edge distance to mortar joints, additional concrete anchors may be required to ensure the "MAX. ON CENTER" dimension are not exceeded.
- Concrete anchor table:

ANCHOR TYPE	ANCHOR SIZE	MIN. EMBEDMENT	MIN. CLEARANCE TO MASONRY EDGE	MIN. CLEARANCE TO ADJACENT ANCHOR
ITW TAPCON®	1/4"	1-1/4"	2"	4"
DeWALT ULTRACON+®	1/4"	1-1/4"	1"	4"

WOOD SCREW INSTALLATION NOTES:

- Maintain a minimum 5/8" edge distance, 1" end distance, & 1" o.c. spacing of wood screws to prevent the splitting of wood.

Documents Prepared By:
Lyndon F. Schmidt
P.E. No. 43409

RW BUILDING CONSULTANTS, INC.
P.O. Box 230, Vairico, FL 33595
Phone No.: 813.659.9197
FBPE Registry No. 9813

PRODUCT: 8800 SERIES VINYL FIXED WINDOW

PART OR ASSEMBLY: BUCK & FRAME ANCHORING

NO.	DATE	REVISIONS
2	7/06/23	UPDATE TO 8TH ED. (2023) FBC LFS
1	7/06/20	UPDATE TO 7TH ED. (2020) FBC LFS
		BY

DATE: 4/07/20

SCALE: N.T.S.

DWG. BY: TJ

CHK. BY: LFS

DRAWING NO.: FL-15816.15

SHEET 3 OF 4

Z:\2023 FBC Drawings\Wincore Window Company\FL-15816 R1\FL-15816.15.dwg

BILL OF MATERIALS		
ITEM #	DESCRIPTION	MATERIAL
A	1X BUCK (SG >= 0.42)	WOOD
B	2X BUCK (SG >= 0.42)	WOOD
C	1/4" MAX. SHIM SPACE	-
D	1/4" X 2-3/4" PFH DeWALT OR ITW CONCRETE SCREW	STEEL
E	MASONRY - 3,000 PSI MIN. CONCRETE CONFORMING TO ACI 301 OR HOLLOW BLOCK CONFORMING TO ASTM C90	CONCRETE
F	#10 X 2" MODIFIED TRUSS HEAD (7/16" Ø) SMS (1-5/16" MIN. EMBEDMENT)	STEEL
G	1/4" X 3-1/4" HWH DeWALT OR ITW CONCRETE SCREW	STEEL
H	1/4" X 2-3/4" HWH DeWALT OR ITW CONCRETE SCREW	STEEL
1	FRAME (PE7701B)*	PVC
2	1" GLAZING BEAD (BV79)*	PVC

* THE APPROVED WHITE RIGID PVC EXTERIOR EXTRUSIONS FOR WINDOWS ARE TO BE PRODUCED BY EXTRUDERS LICENSEES IN "AAMA CERTIFICATION PROGRAMS FOR RIGID PVC EXTRUSIONS".

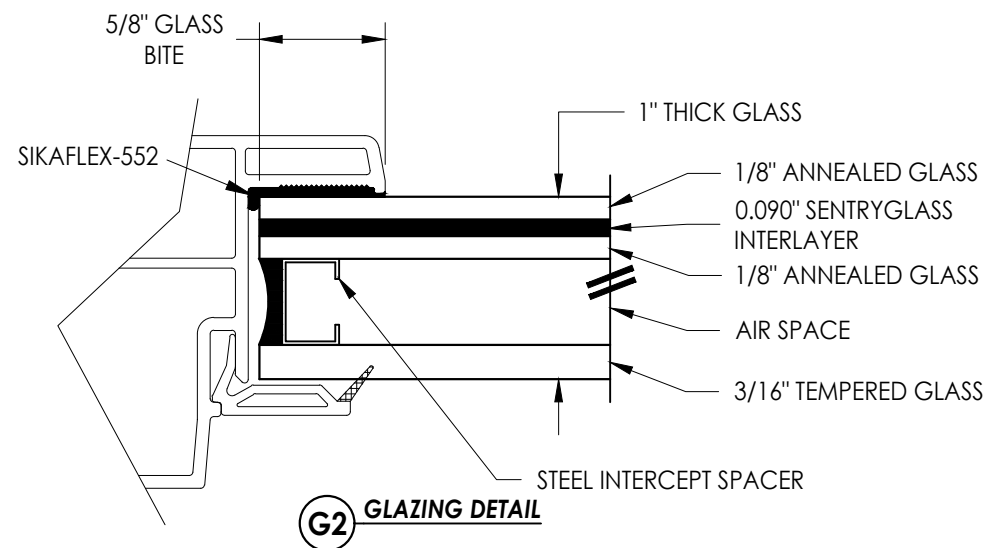
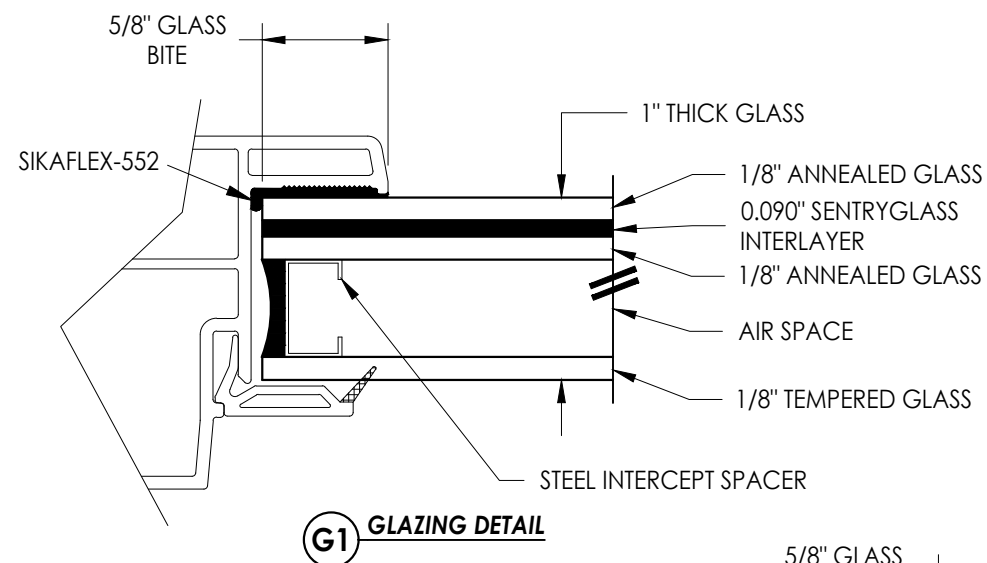
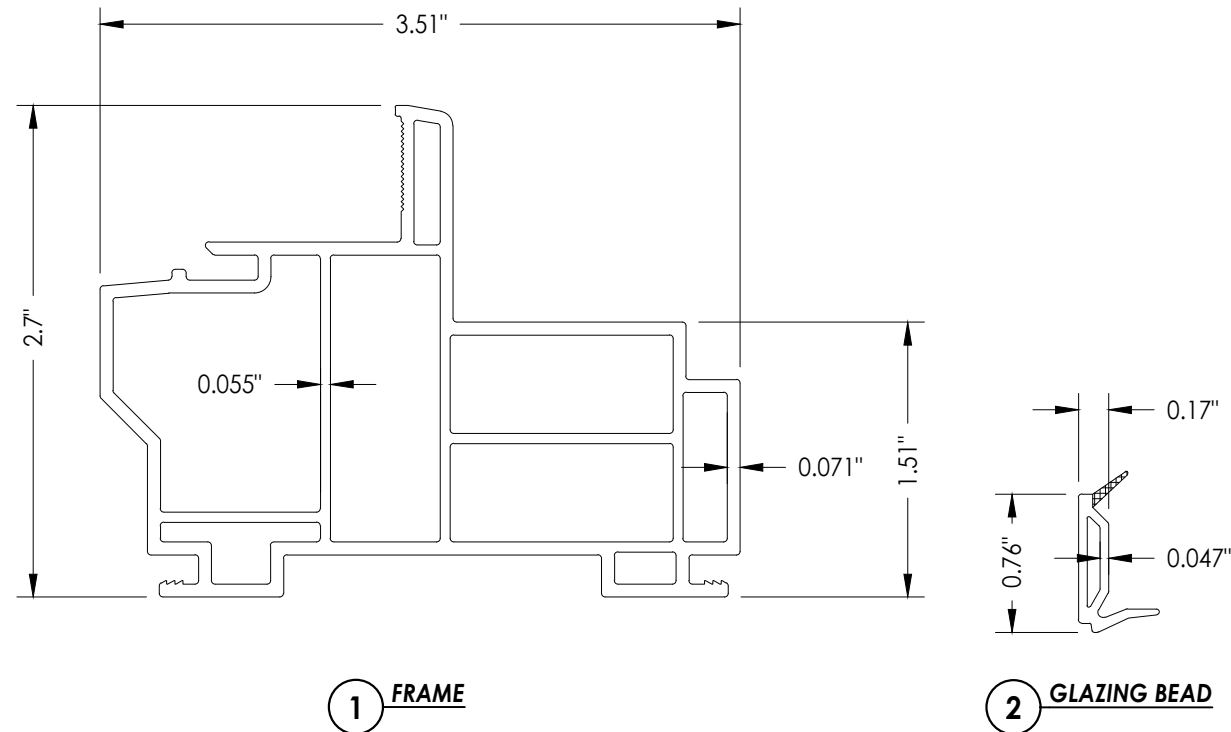

NOTE: GLAZING > 36" WIDE REQUIRES TWO (2) SETTING BLOCKS CONFORMING TO FBC SECTION 2411.3.3.1.

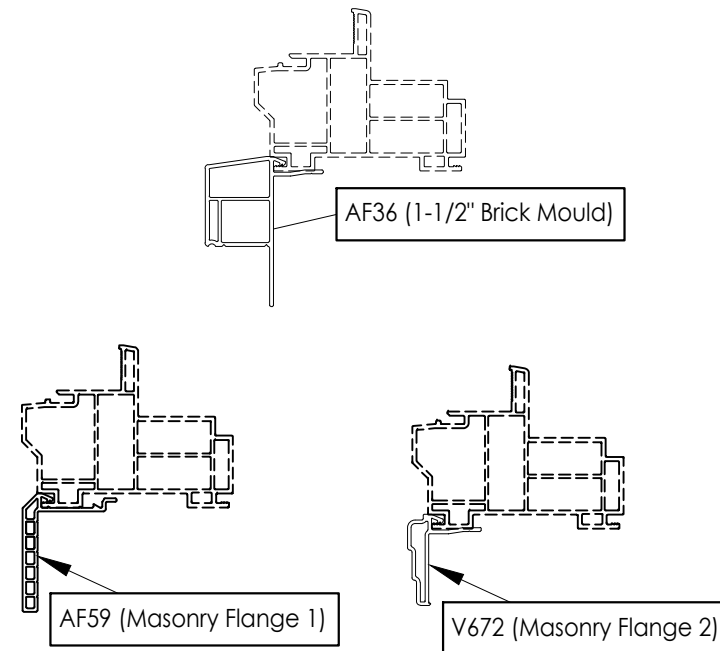

OPTIONAL COSMETIC FLANGES

Documents Prepared By:
Lyndon F. Schmidt
P.E. No. 43409

RW BUILDING CONSULTANTS, INC.
P.O. Box 230, Valrico, FL 33595
Phone No.: 813.659.9197
FBPE Registry No. 9813

PRODUCT: 8800 SERIES VINYL FIXED WINDOW
PART OR ASSEMBLY: BILL OF MATERIALS AND COMPONENTS

NO.	DATE	BY	REVISIONS
2	7/06/23	LFS	UPDATE TO 8TH ED. (2023) FBC
1	7/06/20	LFS	UPDATE TO 7TH ED. (2020) FBC

DATE: 4/07/20
SCALE: N.T.S.
DWG. BY: TJ
CHK. BY: LFS
DRAWING NO.: FL-15816.15
SHEET 4 OF 4